



**Direct Vent Gas Insert**

**Model 739DVN(Natural Gas)**

**Model 739DVP (Propane Fuel)**

**Installation and Owner's Manual**

**INSTALLER: PLEASE LEAVE THIS MANUAL WITH THE CUSTOMER  
CUSTOMER: PLEASE KEEP INSTRUCTIONS FOR FUTURE REFERENCE**

<p align="center"><b>FOR YOUR SAFETY</b></p> <p><b>DO NOT</b> store or use gasoline or any other flammable vapors or liquids in the vicinity of this or any other appliance.</p> <p><b>IF YOU SMELL GAS:</b></p> <ul style="list-style-type: none"> <li>- Do not try to light any appliance.</li> <li>- Open windows.</li> <li>- Do not touch electrical switches.</li> <li>- Do not use any phone in your building.</li> <li>- Extinguish any open flame.</li> <li>- Immediately call your gas supplier from a neighbor's phone. Follow the gas supplier's instructions.</li> <li>- If you cannot reach the gas supplier, call the fire department.</li> </ul>	<p align="center"><b>PLEASE READ INSTRUCTIONS CAREFULLY BEFORE INSTALLING AND OPERATING THE APPLIANCE</b></p> <p><b>WARNING:</b> If the information in these instructions are not followed exactly a fire or explosion may result causing property damage, personal injury or loss of life.</p> <p>Installation and service must be performed by a qualified installer, service agency or the gas supplier.</p> <p>This appliance is suitable for installation in a bedroom or bed sitting room.</p>
-----------------------------------------------------------------------------------------------------------------------------------------------------------------------------------------------------------------------------------------------------------------------------------------------------------------------------------------------------------------------------------------------------------------------------------------------------------------------------------------------------------------------------------------------------------------------------------------------------------------------------------------------------------------	------------------------------------------------------------------------------------------------------------------------------------------------------------------------------------------------------------------------------------------------------------------------------------------------------------------------------------------------------------------------------------------------------------------------------------------------------------------------------------------------------

**This appliance may be installed in an aftermarket permanently located, manufactured (mobile) home, where not prohibited by local codes. This appliance is only for use with the type of gas indicated on the rating plate. This appliance is not convertible for use with other gases, unless a certified kit is used.**

**Made In Canada by  
Miles Industries Ltd  
829 Third Street West  
North Vancouver  
B.C. Canada V7P 3K7**

# TABLE OF CONTENTS

INTRODUCTION.....	3
APPLIANCE DIMENSIONS.....	4
SAFETY INFORMATION.....	5 - 6
SPECIFICATIONS.....	7
PLANNING.....	8
MASONRY CLEARANCES.....	9 - 10
VENTING.....	11 - 12
PACK CONTENTS.....	13 - 15
APPLIANCE PREPARATION.....	16 - 17
GAS SUPPLY.....	18
PANEL INSTALLATION.....	19
LOG INSTALLATION.....	20 - 21
DOOR RE-FITTING.....	22
BURNER & PILOT.....	22
TRIM INSTALLATION.....	23
FINAL CHECKS.....	24
OPERATION WARNINGS.....	25
LIGHTING INSTRUCTIONS.....	26
MAINTENANCE.....	27 - 28
TROUBLE SHOOTING.....	29 - 30
NOTES.....	31

# INTRODUCTION

Thank you for purchasing the model 739 direct vent insert. This high quality unit is specifically designed to be used where installs are restricted by the size of the fireplace. It is our goal to satisfy every Valor customer. This owner's manual explains the steps required to safely assemble, install, operate, and maintain your new appliance.

## Options

The model 739 base unit is supplied equipped for use for either natural gas 739DVN or propane fuel 739DVP.

### Appliance styles

Standard metal front. Black	-	Kit #741SFB
Cast iron front. Black	-	Kit #742CFB

### Optional outer trims

3 sided Contour Trim Kit (Black)	-	Kit #746CTK
3 sided Deluxe Trim Kit (Black)	-	Kit# 747DTK

### Additional optional features

#### **Circulating fan**

Having two speed and temperature control, it is designed to boost the natural convection process through the appliance. It may be fitted before the fireplace is installed or retrofitted at a later date.

**Kit #555CFK**

#### **Natural Gas**

#### **Conversion kit**

For conversion from propane to natural gas intended primarily for post installation conversion in areas where natural gas was not available at the time of initial installation.

**Kit #608NGK**

### Venting options

#### **Direct vent installations**

One or more of the accessories listed below must be used for each installation. see vent installation for details.

**991** Dura-vent DV GS high wind vertical termination cap.

**980** Dura-vent DV GS low profile vertical termination cap.

**930** Dura-vent DV GS Extended vertical termination cap.

**923GK** Dura-vent DV GS Chimney liner termination kit (does not include liner).

**2150** Dura-vent DV GS 3" flex connector

**923F** Dura-vent DV GS 3" co-liner appliance connector.

**Listed** 3" flex pipe (for air intake).

**Listed** 3" flex pipe (for exhaust outlet).

# APPLIANCE DIMENSIONS

See section on installation for details regarding clearances and mantle height allowances.

## 1. Appliance Dimensions

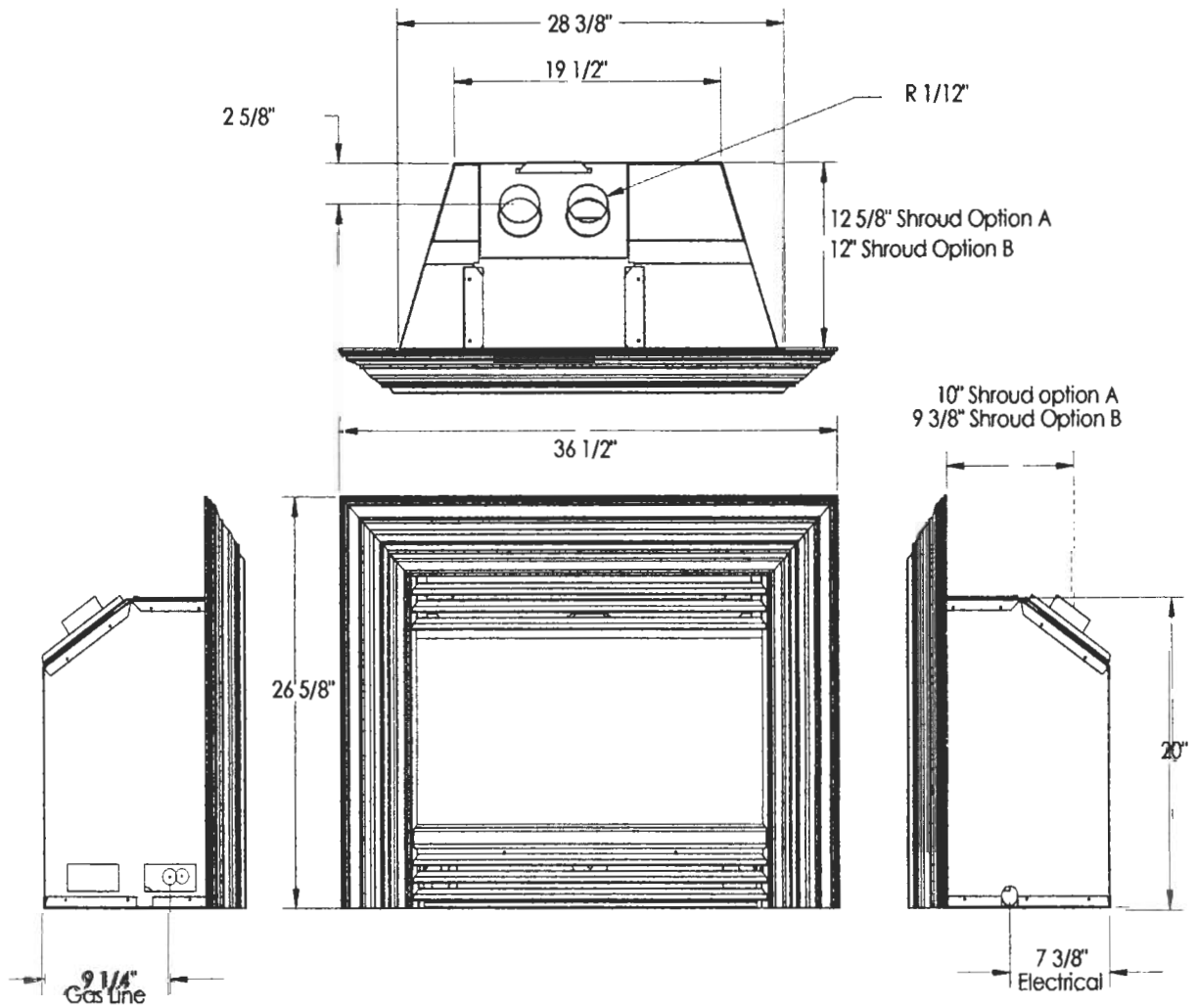

\*\* See Page 9 for clearance information\*\*

## **SAFETY INFORMATION**

**IF THIS APPLIANCE IS NOT PROPERLY INSTALLED, A HOUSE FIRE, OR EXPLOSION MAY RESULT. FOR YOUR SAFETY, FOLLOW THE INSTALLATION DIRECTIONS. CONTACT LOCAL BUILDING OR FIRE OFFICIALS ABOUT RESTRICTIONS AND INSTALLATION REQUIREMENTS IN YOUR AREA. PLEASE READ THIS ENTIRE MANUAL BEFORE YOU INSTALL AND USE YOUR NEW APPLIANCE. FAILURE TO FOLLOW INSTRUCTIONS MAY RESULT IN PROPERTY DAMAGE, BODILY INJURY OR DEATH.**

**Safe installation and operation always require common sense. We are also required by Canadian and ANSI safety standards to point out the following:**

**INSTALLATION AND REPAIR SHOULD BE DONE BY A QUALIFIED SERVICE PERSON. THE APPLIANCE SHOULD BE INSPECTED BEFORE USE AND AT LEAST ANNUALLY BY A PROFESSIONAL SERVICE PERSON. MORE FREQUENT CLEANING MAY BE REQUIRED DUE TO EXCESSIVE LINT FROM CARPETING, BEDDING MATERIAL, ET CETERA. IT IS IMPERATIVE THAT CONTROL COMPARTMENTS, BURNERS AND CIRCULATING AIR PASSAGEWAYS OF THE APPLIANCE BE KEPT CLEAN.**

**IT IS IMPERATIVE THAT CONTROL COMPARTMENTS, BURNERS AND CIRCULATING AIR PASSAGEWAYS OF THE APPLIANCE ARE KEPT CLEAN.**

**DUE TO HIGH TEMPERATURES, THE APPLIANCE SHOULD BE LOCATED OUT OF TRAFFIC AND AWAY FROM FURNITURE AND DRAPERIES.**

**DO NOT USE THIS HEATER IF ANY PART HAS BEEN UNDER WATER. IMMEDIATELY CALL A QUALIFIED SERVICE TECHNICIAN TO INSPECT THE HEATER AND TO REPLACE ANY PART OF THE CONTROL SYSTEM AND ANY GAS CONTROL WHICH HAS BEEN UNDER WATER.**

**THE APPLIANCE AREA MUST BE KEPT FREE FROM COMBUSTIBLE MATERIALS, GASOLINE AND OTHER FLAMMABLE VAPORS AND LIQUIDS.**

**CLOTHING OR OTHER FLAMMABLE MATERIALS SHOULD NOT BE PLACED ON OR NEAR THE APPLIANCE.**

**"THE FLEXIBLE CORD PROVIDED MUST BE CONNECTED TO A LINE VOLTAGE ELECTRICAL SUPPLY".**

**ANY SAFETY SCREEN OR GUARD REMOVED FOR SERVICING A ROOM HEATER MUST BE REPLACED PRIOR TO OPERATING THE APPLIANCE.**

**NEVER VENT THE APPLIANCE INTO OTHER ROOMS OR BUILDINGS. THE APPLIANCE MUST BE VENTED ONLY TO THE OUTSIDE.**

**THIS APPLIANCE MUST NOT BE CONNECTED TO A CHIMNEY FLUE SERVING A SEPARATE SOLID-FUEL BURNING APPLIANCE.**

**CHILDREN AND ADULTS SHOULD BE ALERTED TO THE HAZARDS OF HIGH SURFACE TEMPERATURES AND SHOULD STAY AWAY TO AVOID BURNS OR CLOTHING IGNITION.**

**YOUNG CHILDREN SHOULD BE CAREFULLY SUPERVISED WHEN THEY ARE IN THE SAME ROOM AS THE APPLIANCE .**

**PROVISION FOR ADEQUATE VENTILATION AIR MUST BE PROVIDED.**

# SAFETY INFORMATION

## **2.1 General safety (home owner)**

- To clean the stove, make sure the appliance is off and cold. Then remove the logs and embers and use a vacuum to clean burner and air openings in the bottom and back of the appliance. Replace the logs and embers.
- Fire Extinguisher: Every home should have at least one fire extinguisher. An approved Class A-B-C extinguisher should be mounted on the wall near an exit and close to the appliance, but not so close that accessibility to the extinguisher could be blocked by a fire. Your local Fire Department can advise you concerning the most appropriate location
- Smoke Detectors & Carbon Monoxide Detectors Install at least one smoke detector on each floor of your home to ensure your safety. It should be located away from the gas appliance and close to the sleeping areas. Follow the smoke detector manufacturers placement installation and maintenance instructions. Your local Fire Department may provide assistance in selecting smoke detectors and CO-detectors. It is strongly recommended, for your family's protection, that a CO-detector be placed in all homes that utilize gas in any form.

## **2.2 Safety for the installer**

- Wear gloves and safety glasses for protection.
- Exercise extreme caution when using ladders or when on roof tops.
- Be aware of electric wiring locations in walls and ceilings.
- Use a back support when doing any heavy lifting.

## **2.3 Vent safety**

- Venting must installed according to local codes and good venting practices.

## **2.4 Electrical code**

These appliances, when installed, must be electrically grounded in accordance with local codes or, in the absence of local codes, with the *National Electrical Code, ANSI/NFPA 70* or the *Canadian Electrical Code, CSA C22.1*.

## **3.1 Planning your installation**

Please note the following key points regarding the location of your appliance:

- A sufficient gas pressure is required to supply the unit with a minimum inlet pressure.
- Allow adequate accessibility clearances for servicing and proper operation.
- Allow adequate clearance to combustibles.
- A suitable power outlet is required to provide power when fitted with a fan.

## **3.2 Listing and codes**

The Valor Model 738 is listed and certified for installation in the U.S.A. and Canada under the following standards:

- ANSI Z21.88-2001b / CSA 2.33-2001b  
*Vented Gas Fireplace Heaters.*
- CAN/CGA-2.17-M91,  
*Gas-Fired Appliances for Use at High Altitudes*

## **3.3 Installation codes**

This appliance must be installed in accordance with local codes or in the absence of local codes follow the *National Fuel Gas Code, ANSI Z223.1* or *Canadian Installation Codes, CAN 1-B149*.

## **3.4 High altitude installation**

When installing this appliance over 4500 ft (1372 m) above sea level in Canada, the appliance must be properly de-rated and installed according to local codes, in the absence of local codes in accordance with CAN/CGA-B149, in Canada. In the US for installations above 2000ft the appliance must be installed in accordance with the current *National Fuel Gas Code, ANSI Z223.1/ NFPA 54*.

# Specifications

**Note: Always check appliance label for correct information**

<b>MODEL 739</b>	<b>Natural Gas (NG)</b>	<b>Propane (LP)</b>
Manifold pressure	3.95in. w.c. (0.98 kPa)	9.5 in. w.c. (2.37 kPa)
Min. supply pressure for purpose of input adjustment	5.0 in. w.c. (1.25kPa)	11.0 in. w.c. (2.75 kPa)
Max. supply pressure for purpose of input adjustment	10.5 in. w.c. (2.6 kPa)	14.0 in. w.c. (3.5 kPa)
Orifice size	Bray Part # 82-650	Bray Part # 92-260
Maximum input rating	24,000 BTU/hr	24,000 BTU/hr
High altitude (US)	0 - 2,000ft. (0 - 610 m) US	0 - 2,000ft. (0 - 610 m) US
High altitude (Canada)	0 - 4,500ft. (0 - 1372 m) Can	0 - 4,500ft. (0 - 1372 m) Can
Electrical Rating	120 V.A.C. System	120 V.A.C. System
Circulating fan	Two Speed	Two Speed
Vent System	3" approved flex	3" approved flex
Log Set	Ceramic (6 Piece)	Ceramic (6 Piece)

# Planning

**5.1 Forward planning:** Will always save you time. The recommended order of installation is as follows:

1. Familiarize yourself with this manual.
2. Check the minimum install dimensions and vent installation.
3. Check your local install codes.
4. Check you have the parts and components necessary to complete the installation.
5. Gas and electrical supplies are ready.
6. Prepare opening (clean chase, level base etc).
7. Install vent.
8. Install base unit and connect vent.
9. Install optional fan.
10. Connect gas and electrical supplies.
11. Install operational components and prepare for first test fire.
12. Check operation of unit.
13. Fit surround (optional) and front kit.
14. Take time to explain operation to customer (most call backs are caused because the customer does not understand the operation of the unit).

**NOTE: THIS APPLIANCE MAY ONLY BE INSTALLED IN A SOLID FUEL BURNING FIREPLACE WITH A WORKING FLUE AND CONSTRUCTED OF NON COMBUSTIBLE MATERIAL.**

# Clearances

## 6.1 Existing fireplace (Masonry or factory built)

The model 739 is intended for installation into masonry or listed factory built fireplaces. Masonry fireplaces must be built according to the requirements of the standards for chimneys, fireplaces, vents and solid fuel burning appliances, NFPA 211 (Latest Edition) or the applicable National, Provincial, State or local codes. Fig 6.1 shows the minimum install dimensions for the model 739.

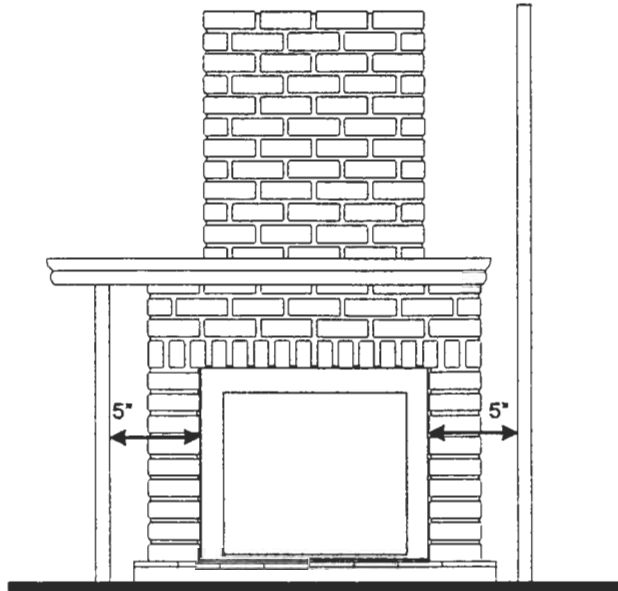

Note: The model 739 is certified without requiring a hearth projection, although local codes may require a minimum hearth projection.

FIGURE 6.1

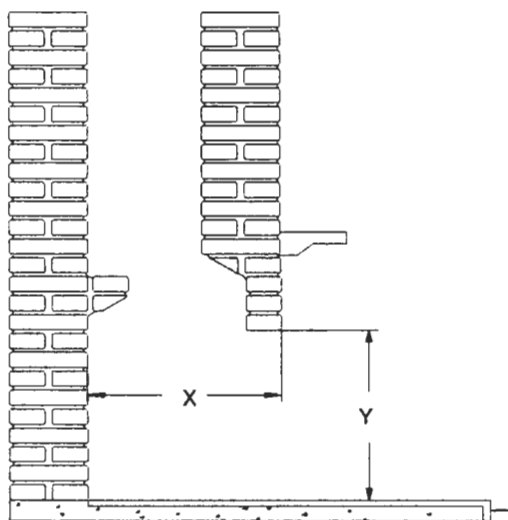

Check masonry step does not interfere with install dimension or vent pipe.

If mantle is combustible see fig 6.2 for allowable clearances.

Minimum width of opening at front of fireplace = 28"

X = 12-5/8" for shroud kit A

X = 12" for shroud kit B

Y = 20"

# Clearances

## 6.2 Mantle Clearance

Fig # 6.2 Shows minimum clearances to combustible mantles.

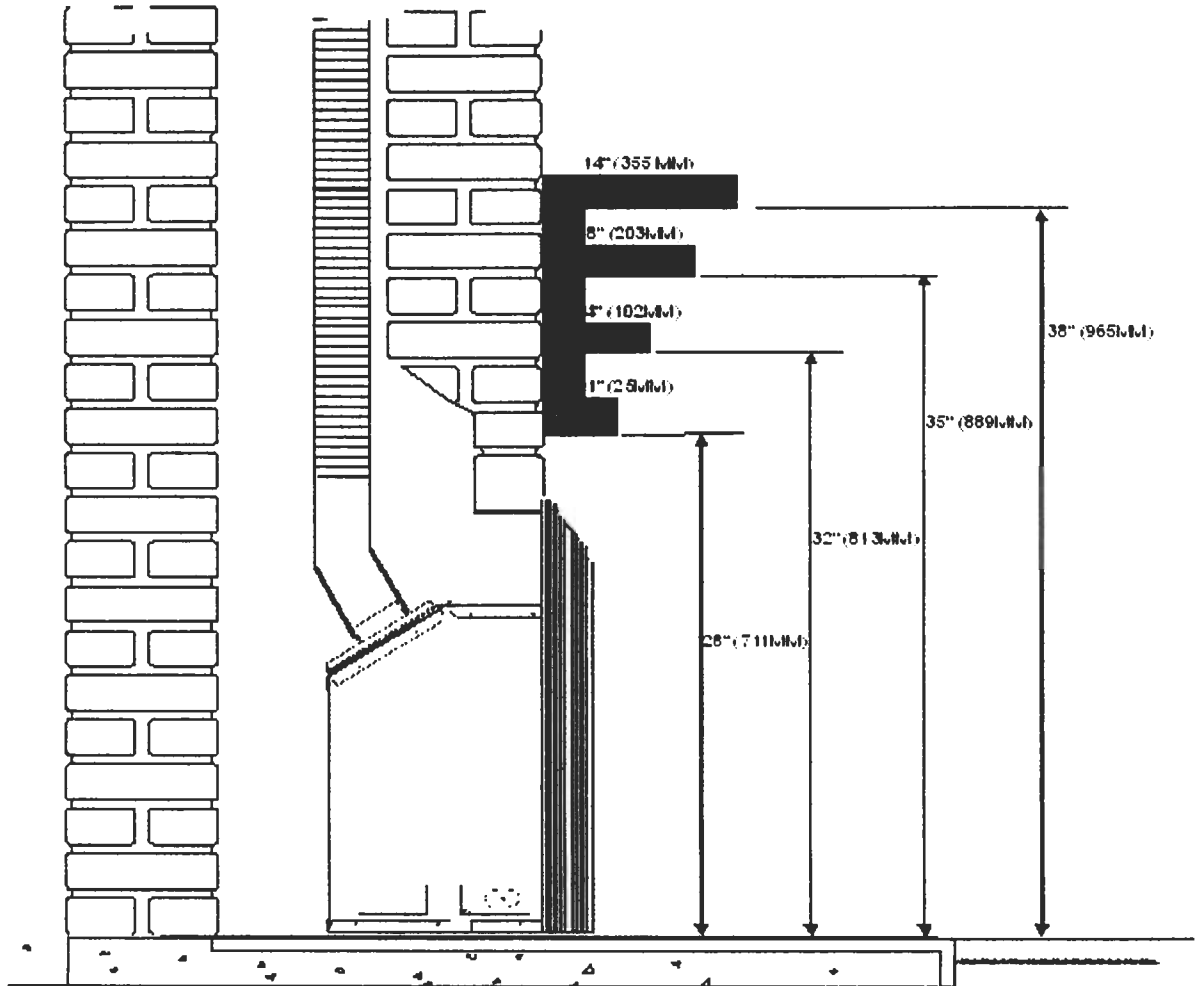

Note: Measurement taken from bottom side of mantel to finish floor surface that the unit is sitting on.

## 6.3 Finishing Materials

**Combustible materials:** Such as wood, compressed paper, plant fibers, plastics or any material capable of igniting and burning, whether flame proofed or not, plaster or un-plastered.

**Non Combustible Material:** Material such as steel, iron brick, tile, concrete or materials that that bear the UL mark for zero (0) fire rating.

# Venting

## 7.1 Vent location

The vent terminal must be located through the roof.

This direct vent appliance is designed to operate when an undisturbed airflow hits the outside vent terminal from any direction.

**Check local codes for allowable vertical vent terminations**

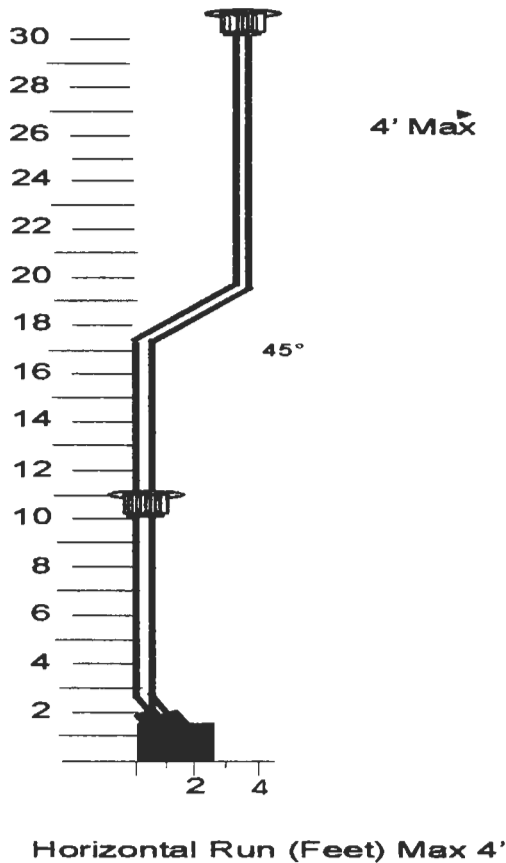

## 7.2 Venting Chart

Maximum vertical height	- 30 ft (measured to bottom of termination)
Minimum vertical height	- 10 ft (measured to bottom of termination)
Maximum horizontal run	- 4 ft (measured center to center of pipe)
Maximum off-set angle	- 45° (sweeping bend to allow for obstructions)

### Venting notes:

Where possible avoid the use of joining flex pipe. If joints are required use the *duravent 923F connector and seal joints with RTV high temp sealant.*

4 ft horizontal is permissible to allow for routing around masonry projections.

Do not bend flex pipe over 45°.

# Venting

## 7.3 Vent installation

**IMPORTANT:** This appliance venting system is room sealed, which means that there should be no provision to allow room air to be used in the combustion process.

**Note:** Use only 3" flex venting materials approved for masonry installation.

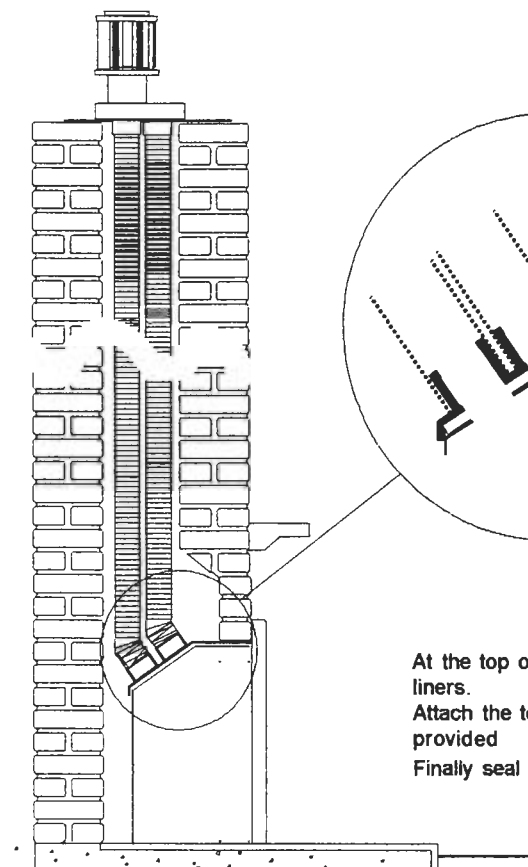

### PLANNING YOUR VENT INSTALLATION

This type of direct vent system may only terminate in the following way: Vertical termination using a duravent 3" adapter and cap (see Vent parts list). There are limitations to the vertical and/or horizontal lengths (see page 11 for venting charts).

When calculating the length of the vent pipe from the outlet of the appliance to termination, allow for any offsets in the chase and sufficient vertical height above the roof.

Apply RTV sealant to the appliance vent pipe and slide over air intake and exhaust pipes.

Secure using the eight self-tapping screws provided (four per flex)

Slide unit into the opening, taking care not to damage the liner (allow enough slack for final surround assembly)

**"WARNING:** Failure to position the parts in accordance with these diagrams or failure to use only parts specifically approved with this appliance may result in property damage or personal injury."

At the top of the chimney slide the connector plate over the two flex liners.

Attach the termination cap to the flex pipes using the eight screws provided

Finally seal the connector plate to the chimney (fire cement).

**Note:** Inspect vent connection prior to installing trim surrounds.

### Typical components used in above install:



991 DV GS cap (high wind)

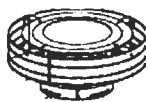

980 DV GS cap (low profile)

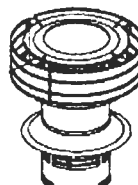

930 DV GS extended cap



2150 DV GS flex connector

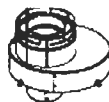

923GK DV GS Chimney liner kit

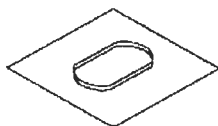

923F DV GS appliance flex connector

## 8. Pack Contents

### **#739DVN or #739DVP Engine unit**

- 1 Appliance engine unit fitted with window
- 1 Ceramic log pack (contains 6 pieces)
- 1 ceramic brick pack ( contains 3 pieces)
- 1 remote control kit ( hand set, reciever and wires)
- 4 1.5V AA batteries
- 1 9V battery
- 2 side shroud fixing brackets
- 1 Top shroud monting bracket
- 1 Gas inlet pipe connection adapter
- 1 rear log support
- 8 #8 screws
- 3 cable clips

### **#741SFB Standard metal front (Alternative)**

- 1 Frame and upper louver unit
- 1 Lower louver unit

### **#742CFB Cast iron front (Alternative)**

- 1 Top casting unit
- 1 Bottom casting unit

### **#555CFK Circulating fan kit (Additional option)**

Details are with the kit

### **#746CTK 3 sided contour trim kit (black)**

- 1 Top trim
- 2 Side trims
- 4 Corner connection plates
- 6 Screws for side trims & engine attachment

### **#747DTK - 3 sided deluxe trim kit (black)**

- 1 Top trims
- 2 Side trims
- 4 Corner connection plates
- 6 Screws for side trims & engine attachment

**Take care when removing the contents from the packaging to prevent damage. Check that all the contents are in the packs and are undamaged.**

# Pack Contents

Ceramic Brick Pack

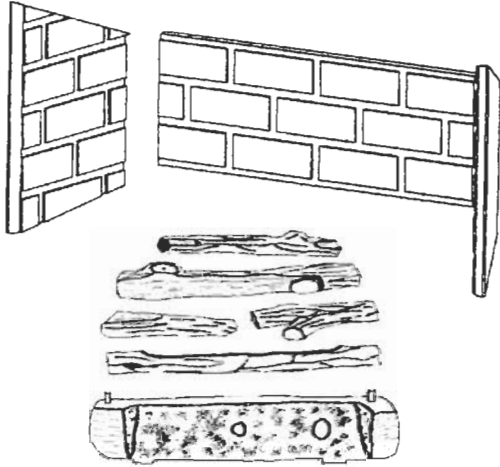

Ceramic Log Set

739 DVN or 739 DVP Engine

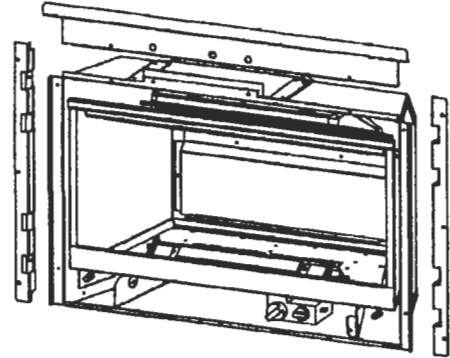

Rear Log Rest

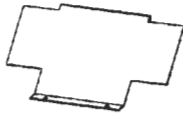

Remote Control

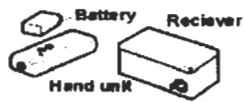

Gas inlet adaptor



Screws

741SFB Standard Metal Front

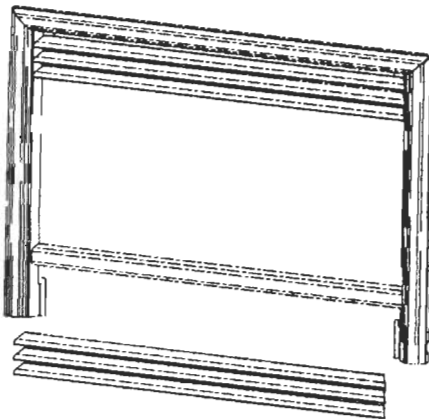

742 CFB Cast Iron Front

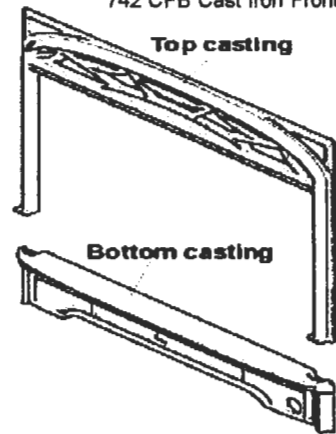

Top casting

Bottom casting

Screw pack

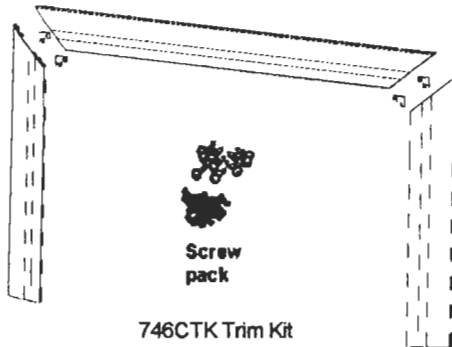

746CTK Trim Kit

Screw pack

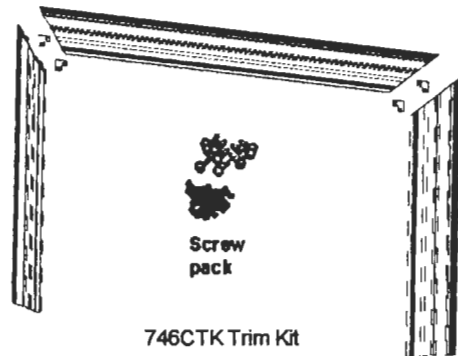

746CTK Trim Kit

# Appliance Preparation

**CAUTION:** Do not abuse the appliance's glass by striking, slamming or similar trauma. Do not use the appliance with the door removed, glass panel cracked or broken. Only use glass approved for use with this heater. Do not use substitute materials. Replacement of the panel should only be carried out by a licensed qualified service person.

Do not remove the door when the appliance is hot. Not only is this dangerous but could cause damage to the gasket.

## 9.1 Window Removal See figure below.

- Remove the bottom center spring loaded screw.
- Turn the 5 remaining spring loaded window bolts through 90 degrees to release the window from the firebox.
- Carefully lift the window away
- Installation is reverse order.

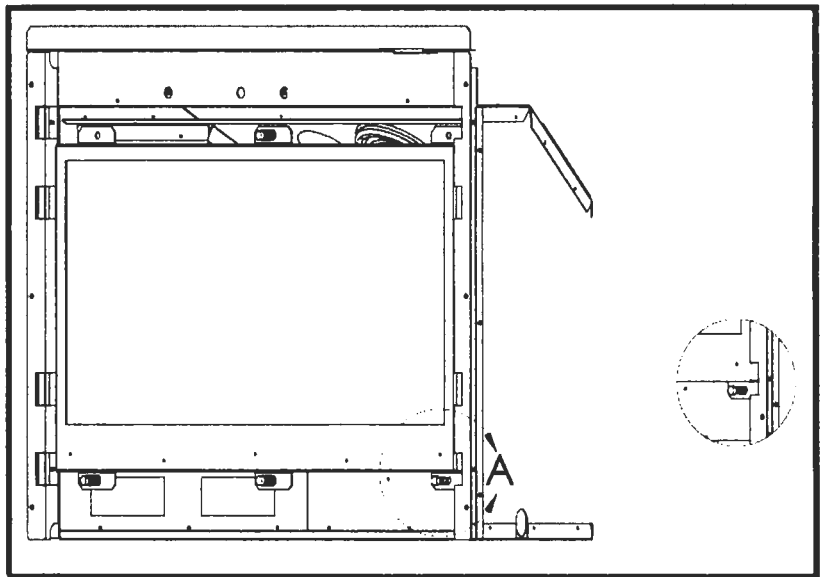

## 9.2 Ignition Spark Check See figure below.

The pilot burner and electrode unit is at the left end of the burner. Push in the lighting knob and turn counter-clockwise through the "IGN" position to "PILOT". A spark should flash across from the pilot electrode to the pilot burner shield.

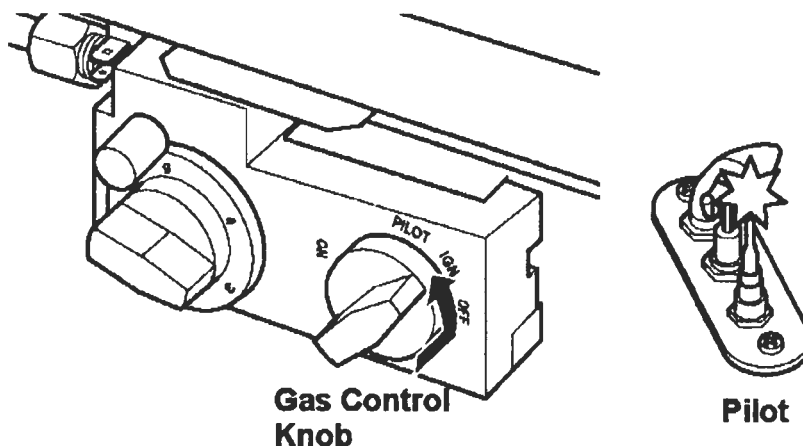

## Remote control Preparation

**Caution!** Don't connect the batteries in the remote control receiver until the wires are connected to the burner control unit. A short circuit could result in destruction of the electrical components.

- Connect wires with the "L" terminals to the tabs at the left side of the control unit.
- Remove the remote control receiver lid.
- Fit four 1.5V batteries.
- Fit the 9V battery to the handset transmitter.
- Place the remote control receiver on the "Velcro" pad .

Remote control operating instructions are supplied with the remote control kit.

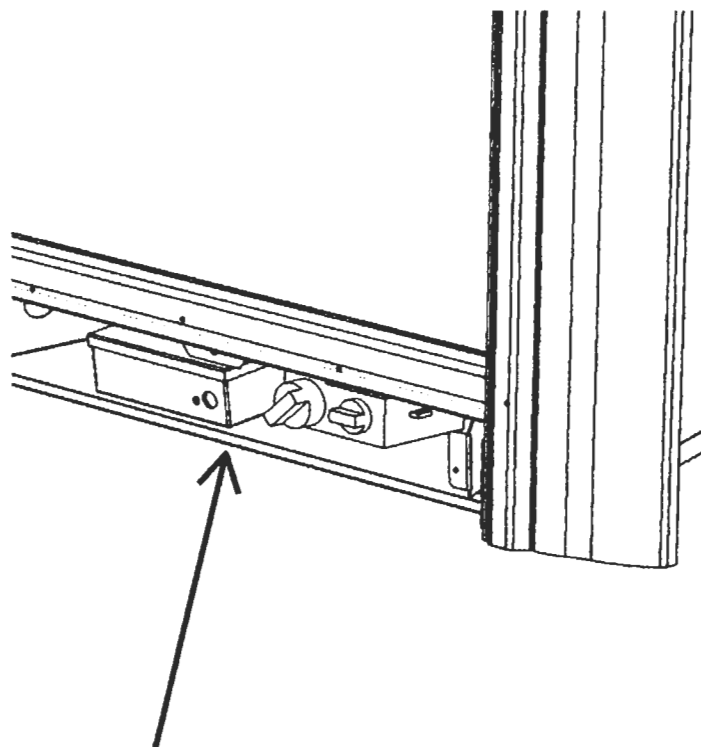

Remote Control Receiver

# Gas Supply

**ONLY PERSONS LICENSED TO WORK WITH GAS PIPING MAY MAKE THE NECESSARY GAS CONNECTION TO THIS APPLIANCE. YOU ARE NOW READY TO HOOK UP THE GAS SUPPLY. BE SURE GAS PLUMBING INSTRUCTIONS AND ALL PROVINCIAL AND LOCAL CODES ARE CAREFULLY FOLLOWED. USE APPROVED FLEXIBLE GAS CONNECTIONS OR RIGID PIPING, DEPENDING ON PROVINCIAL AND LOCAL CODES, TO ATTACH BURNER TO GAS SUPPLY. BE SURE TO USE PROPER SIZE GAS SUPPLY LINE. CAREFULLY CHECK ALL CONNECTIONS FOR GAS LEAKS WITH SOAP AND WATER SOLUTION.**

**EACH INSTALLATION MUST CONFORM TO ALL LOCAL, PROVINCIAL AND NATIONAL CODES. REFER TO THE NATIONAL FUEL GAS CODE, LOCAL ZONING AND CODE AUTHORITIES FOR DETAILS ON INSTALLATION REQUIREMENTS.**

## 11.1 Existing gas supply

Before interrupting the existing gas supply it is recommended that the following be checked.

- ♦ Shut down all gas appliances and carry out a pressure test to insure there are no existing leaks on the system.
- ♦ Before connecting the appliance to the gas supply line, double check that the appliance you have purchased is designed for the gas type you are using. The gas type markings are located on the certification label and also on the appliance's gas valve.
- ♦ Check the gas pressure to insure you will be able to supply the minimum inlet pressure for the appliance.  
Check your pipe sizing to insure sufficient volume will be supplied to the appliance.

## 11.2 Gas supply installation

Provide adequate clearance for proper installation and checking of the gas connections.

Have your gas supplier or a qualified gas fitter run a gas supply line into the gas fireplace. The line must be properly sized and fitted according to the installation codes. Upstream of the appliance supply connection, the fitter shall provide an easily accessible manual shut-off valve.

The gas supply pipe should enter the appliance case through the opening at the rear left side. The supply pipe should be connected to the appliance gas inlet pipe situated at the left side of the control unit. Supply line connection to the inlet pipe is 3/8 NPT.

*If the circulating fan is to be installed, be aware that the supply pipe run inside the case should be at the same height as the appliance inlet pipe in order to clear the fan. If intending to fit an internal isolating valve, check that it will be clear of the fan.*

Use only new black iron or steel pipes or copper tubing if acceptable - check local codes. **Note that in USA copper tubing must be internally tinned for protection against sulfur compounds.**

Unions in gas lines should be of ground joint type. Sealant used must be resistant to the action of all gas constituents including LP gas. Sealant should be applied lightly to male threads to ensure excess sealant does not enter gas lines.

## 11.3 Pressure testing the supply line for leaks

The appliance and its individual shut-off valve must be disconnected from the gas supply piping system during any pressure testing of that system at test pressures in excess of 1/2 psig (3.5 kPa). The appliance must be isolated from the gas supply piping system by closing its individual manual shut-off valve during any pressure testing of the gas supply piping system at test pressures equal to or less than 1/2 psig (3.5 kPa). Failure to do so will damage the appliance's gas valve. Such damage is not covered by the manufacturer's warranty.

When testing for leaks:

- Make sure that the appliance is turned off.
- Open the manual shut-off valve.
- Test for leaks by applying a liquid detergent or soap solution to all joints. Bubbles forming indicate a gas leak.
- **Never use an open flame to check for leaks.**
- Correct any leak detected immediately.
- The pressure test tapping locations are shown in figure 34.

A built-in non-adjustable regulator controls the burner manifold pressure. The correct pressure range is shown in the table in section #4 of this manual. The pressure check should be made with the burner lit. See lighting instruction section for full operating details.

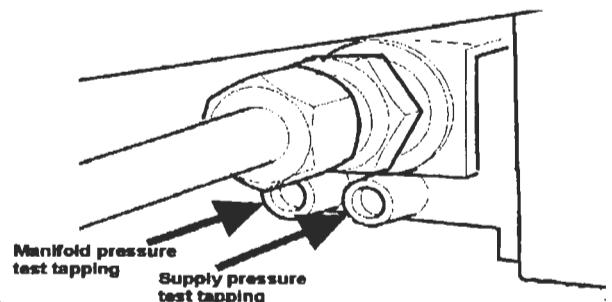

**BE SURE TO TIGHTEN THE PRESSURE TAP SET-SCREW AFTER CHECKING THE PRESSURE. CHECK ALL GAS CONNECTIONS FOR GAS LEAKS.**

## Panel Installation

Rear Brick Panel Rest

1. Remove the Firebox Baffle by first removing 2 screws on the front flange and lifting the Baffle towards you.

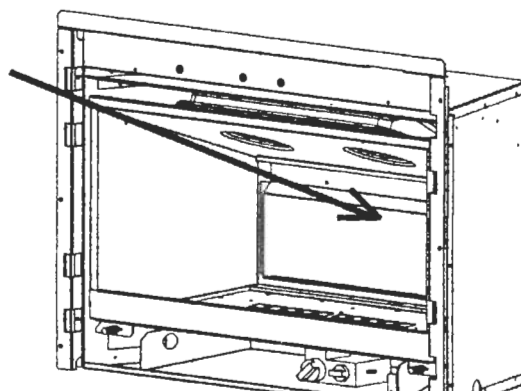

2. Position the Rear Ceramic Panel onto the Rear Brick Panel Rest. The panel will sit on the lower ledge and be flat against the rear of the firebox.

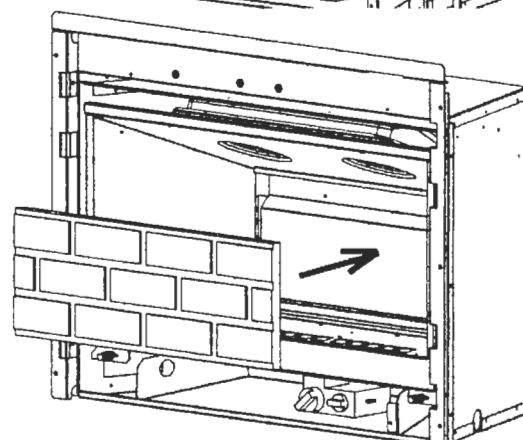

3. Slide the Left Ceramic Panel against the left side of the firebox and up to the Rear Ceramic Panel. The panel will have to be angled to fit inside the firebox. Position the Right Ceramic Panel in the same fashion.

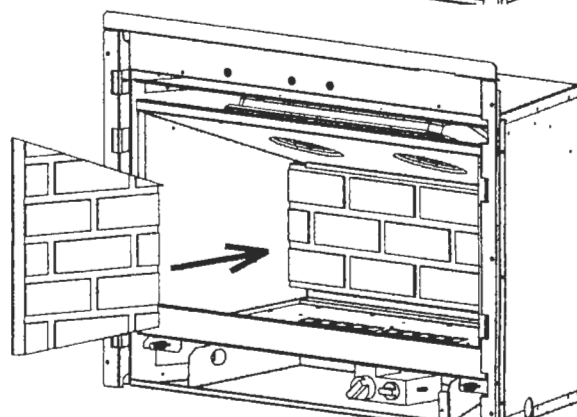

4. Install the Firebox Baffle fitting the rear flange above the Rear Brick Panel Rest and fastening 2 screws provided on the front end.

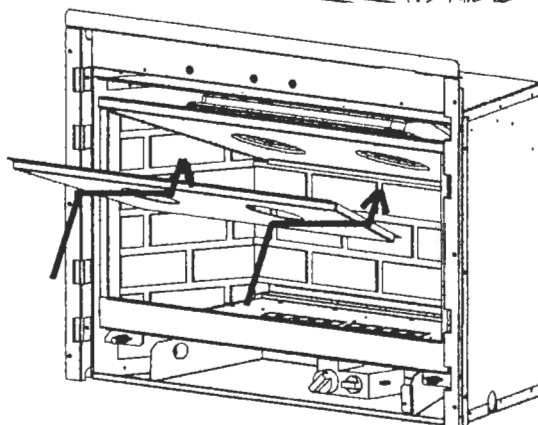

# Log Installation

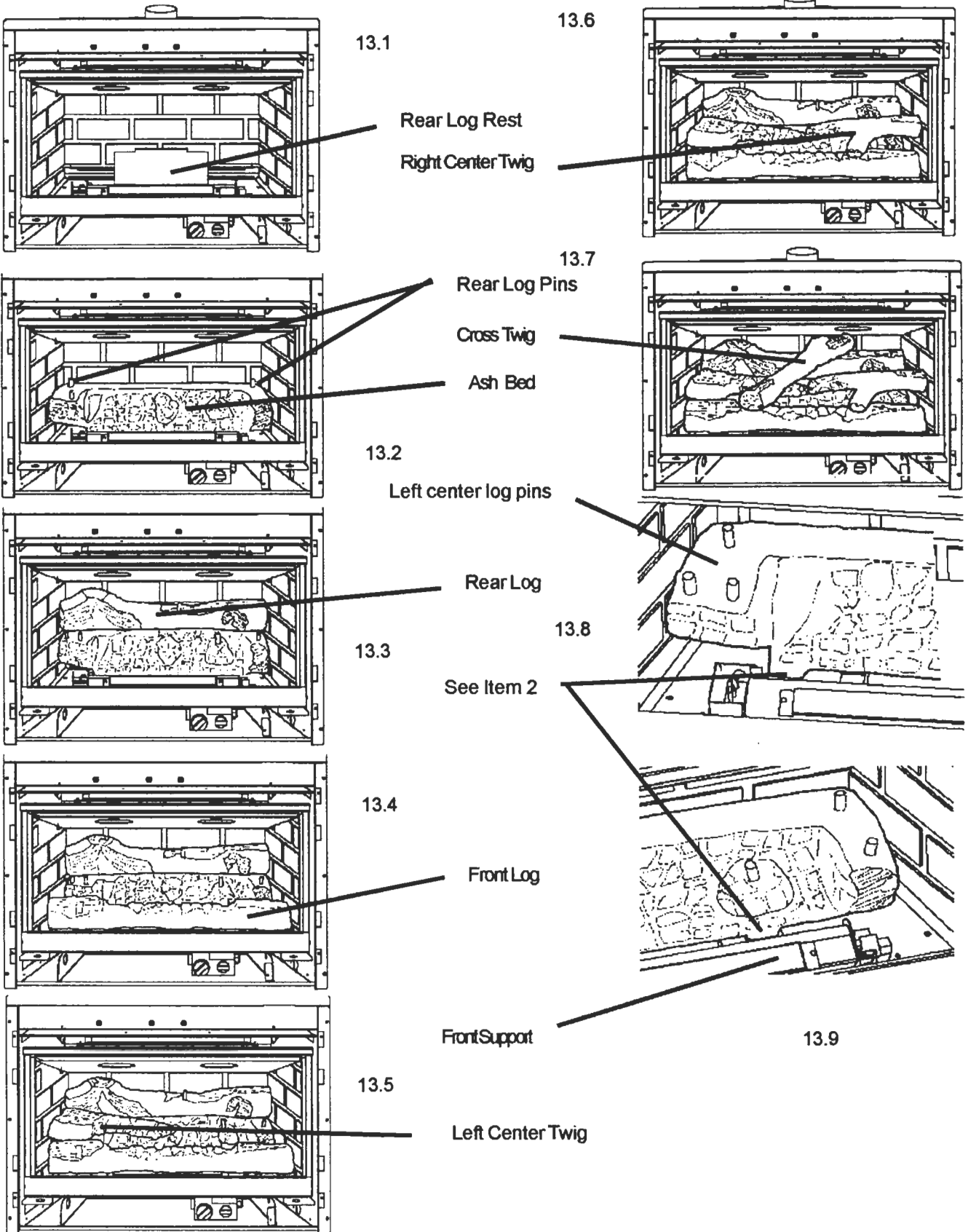

# Log Installation

## **13.1 Ceramic Logs Installation**

1. Install the Log Rest supplied using 3 screws provided. Fig 13.1
2. Place the ash bed in position. The projections at the front of the Ash Bed locate against the sloping metal stops immediately behind the burner. See figure 13.2, 13.8, 13.9
3. Place the Rear Log in position. Locate the log on the 2 pins on the top left and right of the ash bed. See figure 13.3.
4. Place the Front Log at the front of the firebox locating on the front support as shown in figure 13.4.
5. Place the Left Side Center Log in position locating the thick part on the left side of the ash bed on the 2 pins provided with its "nose" resting on top of the ash bed center projection. See figure 13.5
6. Identify the Right Side Center 'Y' log. . Place the Right Side Center Log in position locating the thick part on the right side of the ash bed on to the pin provided with its "nose" located on the single pin. Fig 13.6
7. Intall the Cross Twig by first mounting the rear of the cross twig on the pin situated on the to of the Rear Log near the center. Then move the front of the cross twig until it finds its location in the cradle provided in the front log. See figure 13.7

## Door Refitting

### 14.1 Window refitting & checking

Re-insert the bottom middle screw of the window and tighten, refit the remaining two bottom bolts by turning them through 90°. Refit the top three bolts securing by turning them through 90°. Pull the top of the window forward and release to check that it opens slightly and returns in the event of a delayed ignition explosion. See figure 44. Similarly check the bottom of the window by pulling it forward and releasing. See adjacent figure.

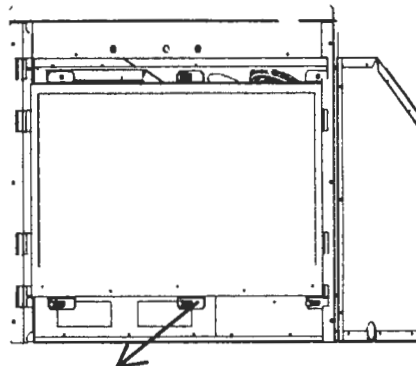
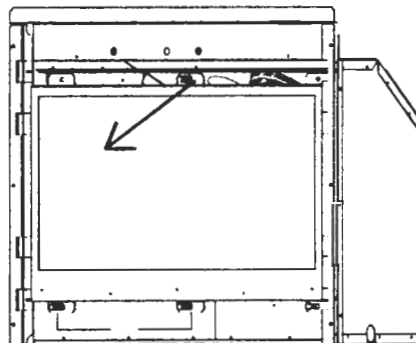

### 14.2 Glass Replacement

In the event that the glass is damaged the door and glass will be replaced only as a complete assembly as supplied by the manufacturer. Remove the broken pieces (be sure to wear gloves) then remove door (see section 9.1 for door removal). Contact manufacturer for replacement door. See section 14.1 for door replacement.

## Burner & Pilot

### 15.1 Burner & pilot checks

Check ignition, pilot stability, burner flames and the full range of the thermostat settings using the rotary switch inside the appliance and all other controls (wall switch, remote hand unit). See owner's lighting instructions further on in this manual for full details.

### 15.2 Aeration adjustment

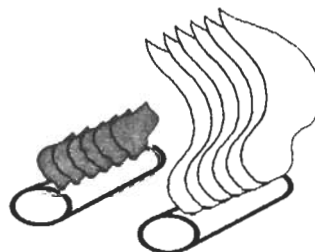
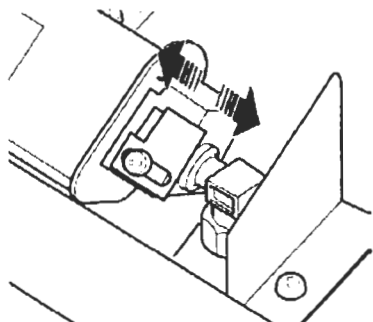

fig 15.2a

As described in section 11, the burner aeration is adjustable. For the vast majority of installations, no adjustment will be necessary. However, in a very few instances, performance may be improved by sliding the shutter to adjust the aeration by (See figure 15.2a). Evaluate the aeration only after the unit has warmed up – approximately 15 minutes. Increasing aeration will cause the flame to appear more transparent and blue making the ceramic fuel effects glow more. Decreasing aeration will cause the flames to appear more yellow or orange making the fuel effects glow less. **Too little aeration may result in black carbon forming and dropping into the firebox.**

# Trim Installation

## 16.1 Side Trim Assembly

- 1) Slide the corner connection plates into the channels in the top trim and a side trim. Butt the two trims together. Fit four grub screws and tighten to secure the trims and corner plate. See figure # 16.1a
- 2) Repeat for the other corner(s).
- 3) Attach the two shroud mounting brackets to the side trims with three screws for each side. The brackets will mount flush to the bottom of each side trim. Figure 16.1b
- 4) Attach the complete trim unit to the firebox with four screws as shown in figure 16.1c

## 16.2 741SFB Standard Metal Front

- 1) After removing standard metal front from packaging, secure to the front of the unit by hanging on the 4 metal tabs as highlighted by detail A on figure 16.2a

## 16.3 742CFB Cast Iron Front

- 1) Attach the bottom casting unit by hooking over the lower tabs at the firebox sides. See figure 16.3a
- 2) Attach the top casting to unit by hooking over the four tabs at the firebox sides as shown in figure 16.3b

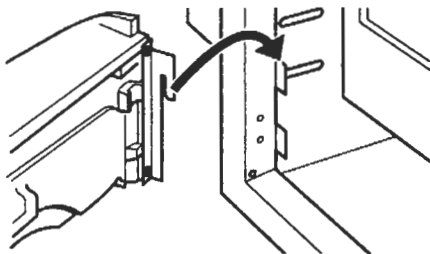

16.3a

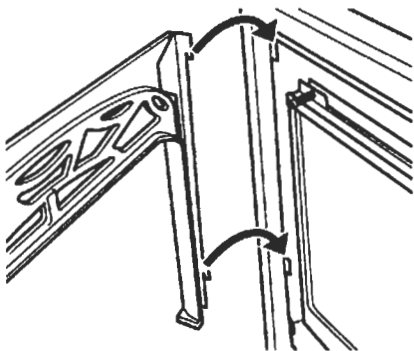

16.3b

16.1a

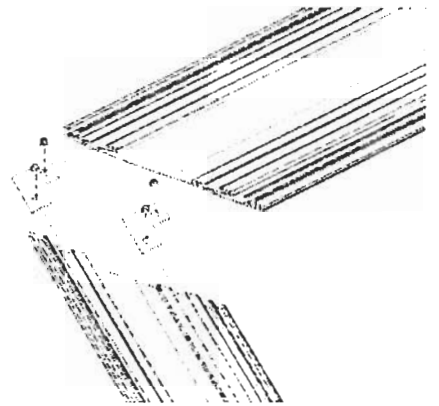

16.1b

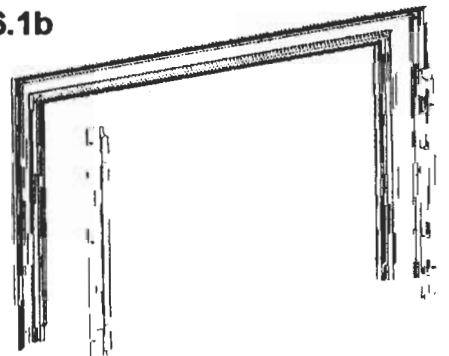

16.1c

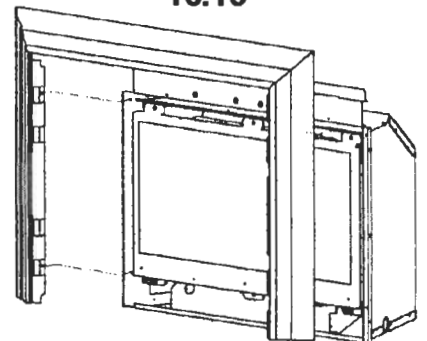

16.2a

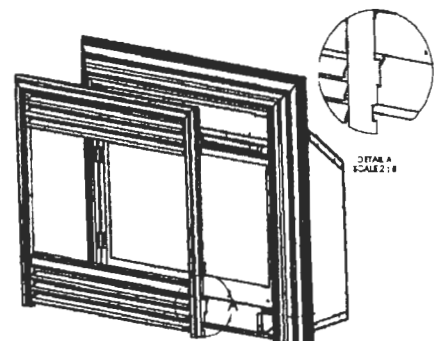

# Final Checks

## 17.1 Final Check

- **INSTALLER:** Before leaving the appliance with the customer, you must check the operation of the appliance:
- Check correct rating by clocking the appliance at 15 minutes (see label).
- Check flame picture. Adjust primary air if required.
- Take time to go through the unit with the customer.
- **NOTE:** When first fired, the unit will produce an odor. This is normal and is part of the paint curing process. It is recommended that you open a few windows to ventilate the room. This will be noticeable for at least 4 hours. During the first hour smoke detectors in the house may be set off.
- Following the initial burn-in period, the glass panel may require cleaning.

**CAUTION:** Do not clean the glass when the appliance is hot!

- When the appliance is fired from cold the glass may fog up. This is due to condensation and is normal.
- Make yourself familiar with these instructions before operating the appliance.
- Check any loose electrical wires that may cause a shock.
- Check around the appliance for gas leaks. IF YOU SMELL GAS, follow the instructions on the front cover of this manual.
- Check to see that logs are correctly positioned. The pilot light should be visible.
- Check to make sure that venting is secure.
- Check all external parts, such as grills, doors and control cover are properly attached and fastened.

**CAUTION:** Do not turn the unit off and on again without a minimum of a 5 minutes wait.

## 17.2 Important - Glass cleaning - Mineral deposits

One of the byproducts of the combustion process in a gas appliance, is a mineral which can show up as a white film on the ceramic glass of the viewing door. The composition of the deposit varies widely from various locations and also from time to time in the same location. You may have the problem for a time and then not see it for many months when it will reappear in your area. It seems this is associated with the varying sulfur content of the gas. We have discussed this problem with ceramic glass manufacturers and they cannot give us a definitive answer to this problem. Dealers have tried various cleaning products with varying results. The following recommendations will not guarantee results in your particular case.

**NOTE:** This is a problem beyond Miles Industries control and is not covered under warranty

- 1) Clean the glass regularly as soon as you notice the buildup (white film). If the film is left for a longer period of time, build up will bake on. It is then much harder, if not impossible, to remove.
- 2) NEVER use an abrasive cleaner on the ceramic glass. Any abrasion of the surface has the immediate effect of compromising the strength of the glass. An emulsion type cleaner is recommended.
- 3) Use a soft damp cloth to apply the cleaner. Dry the glass with a soft, dry, preferably cotton cloth. Most paper towels and synthetic materials are abrasive to ceramic glass and should be avoided.
- 4) Our dealers have had good results from the products listed below.

We can not however guarantee the results of these products.

- a) BRASSO
- b) POLISH PLUS by KEL KEM
- c) COOK TOP CLEAN CREME by ELCO
- d) WHITE OFF by RUTLAND

## 17.3 Operating Your Fire

*The operating instructions are also on a chained plate inside the control access door.*

For your safety, this appliance is fitted with a flame supervision device, which will shut off the gas supply if, for any reason, the pilot flames go out. This device incorporates a fixed probe, which senses the heat from the pilot flame. If the probe is cool, the device will prevent any gas flow unless the burner control knob is kept pushed in at the PILOT position. See full lighting instructions on page 24.

When first turned on, the decorative flames will appear predominantly blue. After approximately 15 minutes the flames will turn yellow.

## Operational Warnings

### Pre- Start Up Checks

**FOR YOUR SAFETY READ - BEFORE LIGHTING**

#### **WARNING**

**IF YOU DO NOT FOLLOW THESE INSTRUCTIONS EXACTLY, A FIRE OR EXPLOSION MAY RESULT CAUSING PROPERTY AND/OR PERSONAL INJURY**

**DO NOT:** Use tools to operate controls, only use your hand to push in and turn the controls.

**DO NOT:** Abuse glass doors by striking or slamming shut.

**DO NOT:** Try to repair the appliance. Call a qualified service technician.

**DO NOT:** Clean the appliance when hot.

**DO NOT:** Use this appliance if any part has been under water. Immediately call a qualified service technician to inspect the appliance and replace any part of the gas control system which has been under water.

**DO NOT:** Use this appliance if you smell gas.

#### **WHAT TO DO IF YOU SMELL GAS:**

- ◆ OPEN WINDOWS.
- ◆ DO NOT TOUCH ANY ELECTRICAL SWITCH; DO NOT USE THE PHONE IN YOUR BUILDING.
- ◆ EXTINGUISH ANY OPEN FLAME.
- ◆ IMMEDIATELY CALL YOUR GAS SUPPLIER FROM A NEIGHBOR'S PHONE AND FOLLOW THE GAS SUPPLIER'S INSTRUCTIONS.
- ◆ IF YOU CANNOT REACH YOUR GAS SUPPLIER, CALL THE FIRE DEPARTMENT.

**“WARNING” Do not operate appliance with the glass front removed, cracked or broken. Replacement of the glass should be done by a licensed or qualified service person.**

Note: The copy in the manual is for reference only. In the event of a discrepancy the label on the unit is to be taken as the latest version.

# Lighting Instructions

## FOR YOUR SAFETY READ BEFORE LIGHTING

**WARNING:** If you do not follow these instructions exactly, a fire or explosion may result causing property damage, personal injury or loss of life.

- A. This appliance has a pilot which must be lighted by hand. When lighting the pilot follow these instructions exactly
- B. BEFORE LIGHTING smell all around the appliance area for gas. Be sure to smell next to the floor because some gas is heavier than air and will settle on the floor.
- WHAT TO DO IF YOU SMELL GAS.
- \* Do not try to light any appliance.
  - \* Do not touch any electric switch; do not use any phone in your building.
  - \* Immediately call your gas supplier from a neighbor's phone. Follow the gas supplier's instructions.
  - \* If you cannot reach your gas supplier, call the fire department.
- C. Use only your hand to push in or turn the control knobs. Never use tools. If the knobs will not push in or turn by hand, don't try to repair them, call a qualified service technician. Force or attempted repair may result in a fire or explosion
- D. Do not use this appliance if any part has been under water. Immediately call a qualified service technician to inspect the appliance and to replace any part of the control system and any gas control which has been under water.

## LIGHTING INSTRUCTIONS.

1. STOP! Read the safety information above on this label.

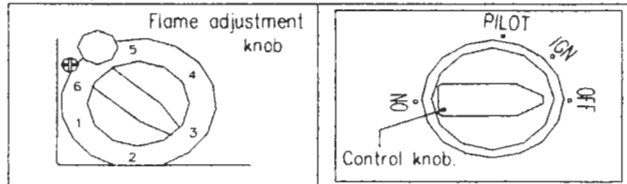

2. Set the flame adjustment knob as far clockwise as possible.\*
3. Turn the control knob clockwise to 'OFF'
- NOTE: Knob cannot be turned from 'PILOT' to 'OFF' unless knob is pushed in partially. Do not force.
4. Wait five (5) minutes to clear out any gas. Then smell for gas including near the floor. If you smell gas, STOP! Follow "B" in the safety information above on this label. If you don't smell gas, go to next step.
5. Find the pilot. It is at the left side of the firebox viewed through hole in front log or coals.
6. Push in and turn the control knob counterclockwise until resistance is felt just before the 'IGN' position.
7. Keep pushed in for a few seconds to allow gas flow then, keeping knob depressed, turn to 'PILOT' to light pilot. Hold knob in for a further 5 seconds then release. The knob should pop back out. Pilot should remain lit. If pilot goes out repeat steps 3 through 7.
- \* If knob does not pop out when released, stop and immediately call your service technician or gas supplier.
  - \* If pilot lights but will not stay lit after several tries, turn the gas control knob to 'OFF' and call your service technician or gas supplier.
8. When pilot is lit, partially depress the knob and turn to 'ON' position. (burner alight)
- \* Do not leave knob set between 'PILOT' and 'ON'
9. Set flame height to desired setting.

## TO TURN OFF GAS TO APPLIANCE.

1. Set the flame adjustment knob as far clockwise as possible.\*
2. Push in control knob slightly and turn clockwise to 'OFF'. Do not force.

\* The flame height can be set by depressing remote control hand set.

DUE TO HIGH SURFACE TEMPERATURES, KEEP CHILDREN, CLOTHING AND FURNITURE AWAY.  
KEEP BURNER AND CONTROL COMPARTMENT CLEAN. SEE INSTALLATION AND OPERATING INSTRUCTIONS  
ACCOMPANYING APPLIANCE.

THIS APPLIANCE MUST BE INSTALLED IN ACCORDANCE WITH LOCAL CODES, IF ANY  
IF NONE, FOLLOW THE NATIONAL FUEL GAS CODE, ANSI Z 233.1, OR CANADIAN  
INSTALLATION CODES, CAN/CGA-B149.

**WARNING:** Improper installation, adjustment, alteration, service or maintenance can cause injury or property damage.  
Refer to the owner's information manual provided with this appliance.  
For assistance or additional information consult a qualified installer,  
service agency or gas supplier.

# Maintenance

**Warning: Use only genuine Valor parts, do not use substitute materials**

## 20.1 Cleaning

It will be necessary to clean the glass periodically. During startup, condensation, which is normal, forms on the inside of the glass and causes dust, lint etc. to cling to the glass surface. Initially paint, while curing, may deposit a slight film on the glass. We therefore recommend that, during the first few weeks of use, the glass is cleaned two or three times with non-abrasive common household cleaners and warm water.

**Ammonia based cleaners should not be used.** Subsequently the glass should be cleaned two or three times a season depending on the circumstances.

**Do not clean the glass while it is hot.**

**Always close the window securely before lighting.**

**Warning: Do not clean the appliance when hot!**

## 20.2 To Clean the Inside of the Glass

Lift, unhook and remove complete steel front assembly.

For cast iron fronts: Lift up and unhook the upper casting and lower casting.

If you have difficulties removing either front please refer to section 16.

Remove the bottom center spring loaded screw. Push in the other two bottom spring loaded bolts and make a quarter turn so that the slots in the bolt heads are horizontal. This will release the bottom of the window.

Push in the top three spring loaded bolts and make a quarter turn so that the slots in the bolt heads are horizontal, lift the door assembly to disengage it with the firebox.

Replacement: Reverse the above procedure to replace the door assembly.

**Always securely fasten the window before lighting.**

## 20.3 To Clean the Ceramic Fuel Effects, Firebox Walls & Burner

Dust, etc. can be brushed from the ceramic fuel effects and firebox walls after removing the front unit and completely removing the window.

Dust etc. can also be removed from the burner using a soft brush after removing the ceramic fuel effects.

Remove the door assembly as described above.

Always completely remove the window before removing the ceramic fuel effects.

When cleaning, make sure that no particles are brushed into the slots in the burner.

Always securely replace the window securely before lighting.

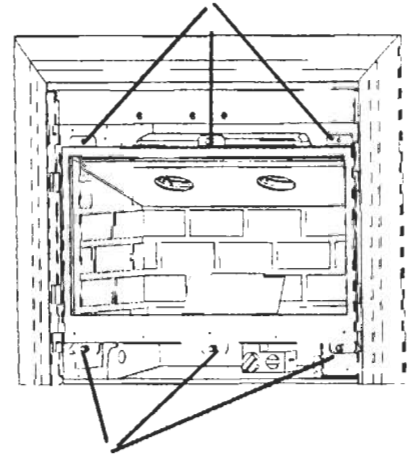

Figure 20.2a

# Maintenance

## 20.4 Checks

1. A periodic check of the pilot and burner flames should be made. Check after the fire has been on for at least 30 minutes. The pilot flame must cover the tip of the thermocouple probe. The main burner flame pattern will vary from appliance to appliance depending on the type of installation and climatic conditions. See figures 20.4a and 20.4b.
2. The appliance area must always be kept clear and free from combustible materials, gasoline and other flammable vapors and liquids.
3. Inspect the vent terminal outdoors regularly to make sure that dirt, snow, insects, leaves etc, do not obstruct it.
4. Examine the whole vent system regularly by a qualified agency. We recommend annually.

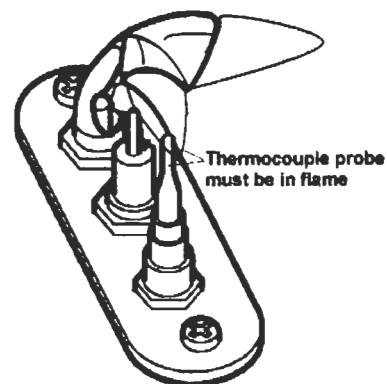

fig 20.4a

## 20.5 General Servicing

If you require any attention to your appliance, contact your supplier quoting the model number. It will be helpful if the appliance serial number can also be quoted. This is on the rating plate, which is on a chained, plate accessible by opening the bottom access panel.

The repair parts are shown in the separate repair parts leaflet. Please always quote part number and description when requesting spare parts.

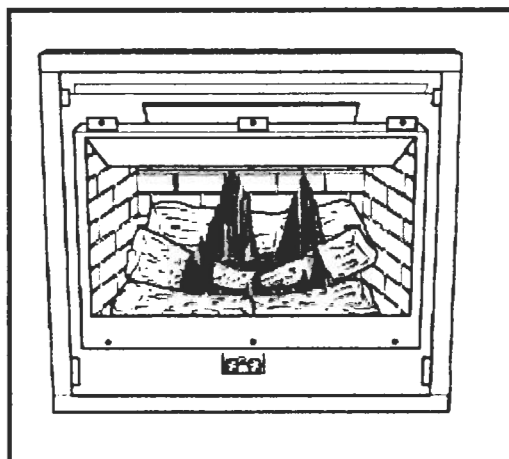

Fig 20.4b

# Trouble Shooting

Please check to make sure the instructions are followed exactly before attempting trouble shooting of the appliance.

**WARNING:** Trouble shooting and servicing of gas and electrical devices of the appliance should only be conducted by a qualified service technician.

**CAUTION:** Label all wires prior to disconnection when servicing controls. Wiring errors can cause improper and dangerous operation. Verify proper operation after servicing.

<b>PROBLEM</b>	<b>POSSIBLE CAUSE</b>	<b>CORRECTIVE ACTION</b>
<p>Pilot will not light after pressing the sparker many times.</p>	<p><i>Air in gas line.</i></p> <p><i>No gas supply.</i></p> <p><i>Piezo wire loose.</i></p> <p><i>Defective Piezo.</i></p> <p><i>Piezo wire grounding.</i></p> <p><i>Electrode grounding.</i></p> <p><i>Electrode gap incorrect.</i></p>	<p>Purge air out of gas line.</p> <p>Check to make sure the gas supply to the appliance is turned on and there is adequate gas supply pressure to the appliance.</p> <p>Check for sparks between the spark electrode and the pilot head when the sparker is pressed. If there are no sparks:</p> <p>Check for broken or poor connection from the sparker to the electrode.</p> <p>Check for the spark shorting or arcing at other locations.</p> <p>Check for defective piezo.</p> <p>Check for defective/cracked spark electrode.</p> <p>With the door removed, try lighting the pilot with a match.</p> <p>Note: If there is no gas or air coming out of the pilot and there is gas pressure to the appliance, the pilot orifice may be blocked or the gas valve maybe defective</p>
<p>Pilot will not remain on after being lit.</p>	<p><i>Poor Pilot flame.</i></p>  <p><i>Faulty thermocouple.</i></p> <p><i>Thermocouple grounding.</i></p> <p><i>Faulty gas valve.</i></p> <p><b>Note: This is very rare and faults blamed on the gas valve are usually incorrect.</b></p>	<p>Check to see if the pilot flame is large enough to reach and surround the thermocouple. If the flame is too small, check for correct gas supply pressure. If pressure is good, adjust the pilot flame size with the adjustment screw on the valve. If the flame cannot be adjusted, there might be some debris obstructing the pilot orifice.</p> <p>Check for correct millivolts at the thermocouple. The thermocouple should generate at least 30 mV.</p> <p>Check for poor connection of the thermocouple to the valve. If readings are correct for thermocouple replace gas valve.</p>
<p>The main burner does not turn on with the pilot lit.</p>	<p><i>Gas valve not in on position.</i></p> <p><i>Faulty remote</i></p>	<p>Check to make sure the control knob is turned to the 'ON' position.</p> <p>Check batteries in the hand set and reciever.</p> <p>Check that the remote is not set to "auto" or "timer".</p>

# Trouble Shooting

<b>PROBLEM</b>	<b>POSSIBLE CAUSE</b>	<b>CORRECTIVE ACTION</b>
Frequent pilot outage problems.	<i>Pilot adjusted too low.</i> <i>Thermocouple worn.</i> <i>Adverse wind conditions.</i>	Adjust pilot and clean if required. Check thermocouple millivolts (see above). Check termination location is not subject to adverse environmental conditions.
The main burner shuts off when the appliance is warm.	<i>Pilot flame lifting off thermocouple.</i>	Check thermocouple voltage from start up. If millivolts drop dramatically it is an indication that the pilot is lifting. Check the vent is correctly attached.
Excessive soot on burner or logs.	<i>Incorrect aeration adjustment.</i> <i>Incorrect venting.</i>	Check aeration setting. Check that venting is correctly attached.
Sharp blue flames lifting off burner.	<i>Incorrect aeration adjustment.</i>	Reduce primary aeration adjustment.